

Trigonometry

Year 10

#MathsEveryoneCan

White  
Rose  
Maths

	Week 1	Week 2	Week 3	Week 4	Week 5	Week 6	Week 7	Week 8	Week 9	Week 10	Week 11	Week 12
<b>Autumn</b>	<b>Similarity</b>						<b>Developing Algebra</b>					
	Congruence, similarity and enlargement			Trigonometry			Representing solutions of equations and inequalities			Simultaneous equations		
<b>Spring</b>	<b>Geometry</b>						<b>Proportions and Proportional Change</b>					
	Angles & bearings		Working with circles		Vectors		Ratios & fractions		Percentages and Interest		Probability	
<b>Summer</b>	<b>Delving into data</b>				<b>Using number</b>				<b>Expressions</b>			
	Collecting, representing and interpreting data				Non-calculator methods		Types of number and sequences		Indices and Roots		Manipulating expressions	

# Autumn 1: Similarity

## Weeks 1 & 2: Congruence, Similarity and Enlargement

Building on their experience of enlargement and similarity in previous years, this unit extends students' experiences and looks more formally at dealing with topics such as similar triangles. It would be useful to use ICT to demonstrate what changes and what stays the same when manipulating similar shapes. Parallel line angle rules are revisited to support establishment of similarity. Congruency is introduced through considering what information is needed to produce a unique triangle. Higher level content extends enlargement to explore negative scale factors, and also looks at establishing that a pair of triangles are congruent through formal proof.

National curriculum content covered (**Higher content in bold**):

- extend and formalise their knowledge of ratio and proportion in working with measures and geometry
- compare lengths, areas and volumes using ratio notation and/or scale factors; make links to similarity
- interpret and use fractional **{and negative}** scale factors for enlargements
- apply the concepts of congruence and similarity, including the relationships between lengths, **{areas and volumes}** in similar figures
- use mathematical language and properties precisely
- make and test conjectures about the generalisations that underlie patterns and relationships; look for proofs or counter-examples
- develop their mathematical knowledge, in part through solving problems and evaluating the outcomes, including multi-step problems

## Weeks 3 to 6: Trigonometry

Trigonometry is introduced as a special case of similarity within right-angled triangles. Emphasis is placed throughout the steps on linking the trig functions to ratios, rather than just functions. This key topic is introduced early in Year 10 to allow regular revisiting e.g. when looking at bearings. For the Higher tier, calculation with trigonometry is covered now and graphical representation is covered in Year 11

National curriculum content covered:

- extend and formalise their knowledge of ratio and proportion, including trigonometric ratios
- apply Pythagoras' Theorem and trigonometric ratios to find angles and lengths in right-angled triangles {and, where possible, general triangles} in two **{and three}** dimensional figures
- know the exact values of  $\sin \theta$ ,  $\cos \theta$ ,  $\tan \theta$  for required angles
- **{know and apply the sine rule and cosine rule to find unknown lengths and angles}**
- **{know and apply to calculate the area, sides or angles of any triangle}**
- develop their mathematical knowledge, in part through solving problems and evaluating the outcomes, including multi-step problems
- make and use connections between different parts of mathematics to solve problems
- model situations mathematically and express the results using a range of formal mathematical representations, reflecting on how their solutions may have been affected by any modelling assumptions
- select appropriate concepts, methods and techniques to apply to unfamiliar and non-routine problems; interpret their solution in the context of the given problem

## Why Small Steps?

We know that breaking the curriculum down into small manageable steps should help students to understand concepts better. Too often, we have noticed that teachers will try and cover too many concepts at once and this can lead to cognitive overload. We believe it is better to follow a “small steps” approach.

As a result, for each block of content in the scheme of learning we will provide a “small step” breakdown. ***It is not the intention that each small step should last a lesson – some will be a short step within a lesson, some will take longer than a lesson.*** We would encourage teachers to spend the appropriate amount of time on each step for their group, and to teach some of the steps alongside each other if necessary.

## What We Provide

- Some ***brief guidance*** notes to help identify key teaching and learning points
- A list of ***key vocabulary*** that we would expect teachers to draw to students’ attention when teaching the small step,
- A series of ***key questions*** to incorporate in lessons to aid mathematical thinking.
- A set of questions to help ***exemplify*** the small step concept that needs to be focussed on.

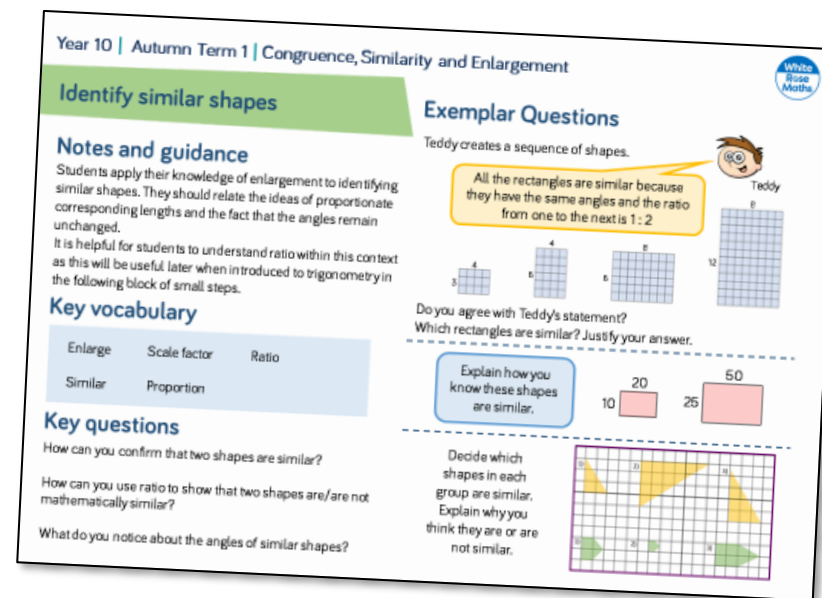

Year 10 | Autumn Term 1 | Congruence, Similarity and Enlargement

### Identify similar shapes

**Notes and guidance**  
Students apply their knowledge of enlargement to identifying similar shapes. They should relate the ideas of proportionate corresponding lengths and the fact that the angles remain unchanged. It is helpful for students to understand ratio within this context as this will be useful later when introduced to trigonometry in the following block of small steps.

**Key vocabulary**

Enlarge	Scale factor	Ratio
Similar	Proportion	

**Exemplar Questions**  
Teddy creates a sequence of shapes.

All the rectangles are similar because they have the same angles and the ratio from one to the next is 1:2

Do you agree with Teddy's statement? Which rectangles are similar? Justify your answer.

Explain how you know these shapes are similar.

Decide which shapes in each group are similar. Explain why you think they are or are not similar.

**Key questions**  
How can you confirm that two shapes are similar?  
How can you use ratio to show that two shapes are/are not mathematically similar?  
What do you notice about the angles of similar shapes?

- These include reasoning and problem-solving questions that are fully integrated into the scheme of learning. Depending on the attainment of your students, you may wish to use some or all of these exemplars, which are in approximate order of difficulty. Particularly challenging questions are indicated with the symbol .
- For each block, we also provide ideas for key representations that will be useful for all students.

Some of the small steps are in **bold** and labelled with **H** to indicate this is Higher tier GCSE content. We would encourage teachers to use these with as many students as possible – if you feel your class can access any particular small step, then please include it in your planning. Steps that review content covered at Key Stage 3 are labelled **R**.

# Key Representations

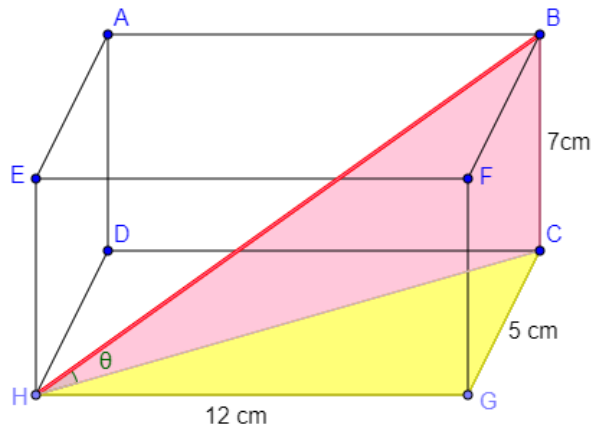
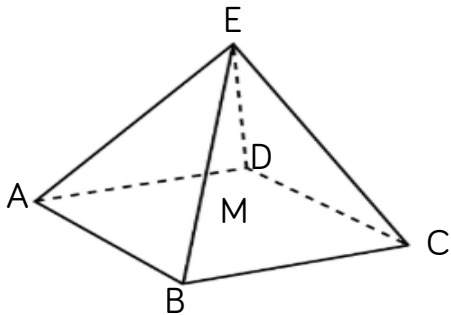
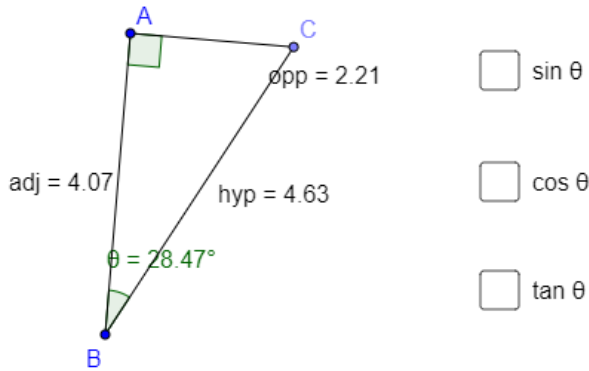
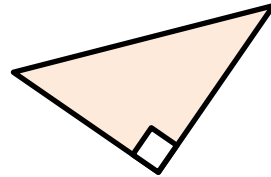
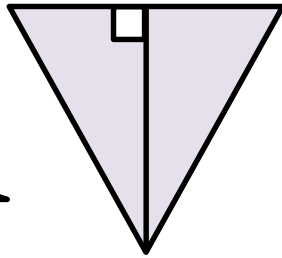
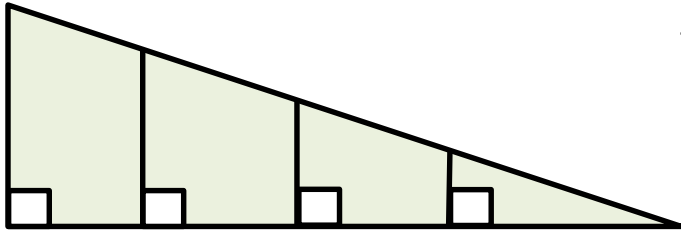

Pictorial representation is essential to support conceptual understanding of enlargement, similarity and congruence.

Students should understand trigonometry as an extension of similar triangles. Drawing and labelling right-angled triangles to represent problems is essential. In addition, they should be able to visualise and sketch diagrams from descriptions. They then build on this with concrete and pictorial representations of 3-D objects.

Dynamic geometry packages are effective in supporting students to understand trigonometry, particularly when explaining why for example,  $\tan 90$  is undefined. Concrete representations are also effective. For example, cocktail sticks and marshmallows can be used to make 3-D representations.

# Trigonometry

## Small Steps

- ▶ Explore ratio in similar right-angled triangles
- ▶ Work fluently with the hypotenuse, opposite and adjacent sides
- ▶ Use the tangent ratio to find missing side lengths
- ▶ Use the sine and cosine ratio to find missing side lengths
- ▶ Use sine, cosine and tangent to find missing side lengths
- ▶ Use sine, cosine and tangent to find missing angles
- ▶ Calculate sides in right-angled triangles using Pythagoras' Theorem R
- ▶ Select the appropriate method to solve right-angled triangle problems

H denotes Higher Tier GCSE content

R Denotes 'review step' – content should have been covered at KS3

# Trigonometry

## Small Steps

- ▶ Work with key angles in right-angled triangles (1) & (2)
- ▶ Use trigonometry in 3-D shapes H
- ▶ Use the formula  $\frac{1}{2}ab \sin C$  to find the area of a triangle H
- ▶ Understand and use the sine rule to find missing lengths H
- ▶ Understand and use the sine rule to find missing angles H
- ▶ Understand and use the cosine rule to find missing lengths H
- ▶ Understand and use the cosine rule to find missing angles H
- ▶ Choosing and using the sine and cosine rules (1) & (2) H

H denotes Higher Tier GCSE content

R Denotes 'review step' – content should have been covered at KS3

# Ratio in right-angled triangles

## Notes and guidance

Students should explore the ratio of two side-lengths in a right-angled triangle, given a specific angle. This facilitates understanding of a constant ratio between a pair of side lengths in relation to a specific angle. Teachers will need to emphasise, through class discussion, the generalisations being made. It may be appropriate to use opposite, adjacent and hypotenuse to discuss the given side lengths.

## Key vocabulary

Enlarge	Scale factor	Ratio
Corresponding	Constant	

## Key questions

When the side-lengths are in the same ratio, what do you notice about the position of these two-side lengths in each triangle? What do you notice about the given angle?

Will the ratio remain constant if the given angle gets bigger/smaller? Why/Why not?

## Exemplar Questions

In the triangles below, a and b have been labelled with specific lengths.

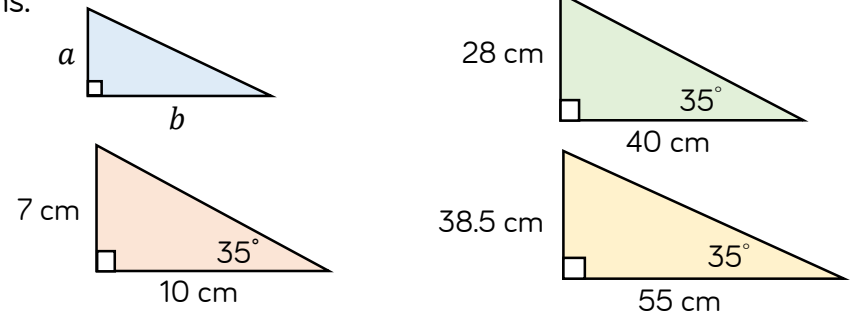

Complete the table.  
What do you notice?  
Will this always happen if the angle is labelled is 35°?

	a	b	$\frac{a}{b}$
Triangle 1			
Triangle 2			
Triangle 3			

Use this generalisation to find the missing value  $x$  in these triangles.



Use the information on the first triangle to find the missing values  $x$  on the following two triangles.

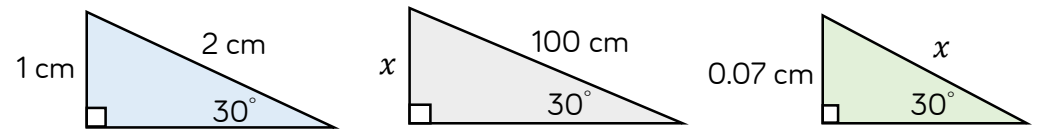



# Hypotenuse, opposite & adjacent

## Notes and guidance

Students need to be able to name the different sides of a right-angled triangle in relation to given angles. Labelling the hypotenuse first is a useful strategy. They should have opportunities to name sides in differently orientated right-angled triangles. Using both acute angles of the triangle can also assist students understanding of which sides to select in relation to an angle.

## Key vocabulary

Adjacent	Opposite
Hypotenuse	Right angle

## Key questions

Why can the same side on a right-angled triangle be labelled the 'opposite' on some occasions, and the 'adjacent' on others?  
 Where can you see a right-angled triangle in this shape? (Give examples of different shapes such as an isosceles triangle, a hexagon, a trapezium, a parallelogram etc.)

## Exemplar Questions

Label the sides of these right-angled triangles.

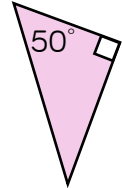
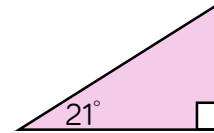
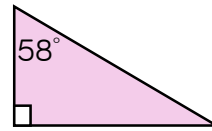

Eva and Jack have been asked to label the sides in relation to the angle marked in red.

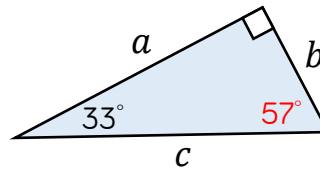

I think  $a =$  opposite,  $b =$  adjacent and  $c =$  hypotenuse

I think  $a =$  adjacent,  $b =$  opposite and  $c =$  hypotenuse

Who's made a mistake? What mistake have they made?

Identify a right-angled triangle which incorporates the angle labelled in red and label its sides.

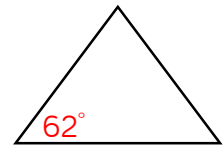
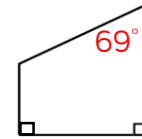
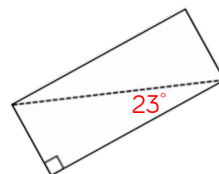

A man walks a mile due East and then a mile due South. He then walks directly back to the start. Draw a right-angled triangle to represent his journey. Using the internal angle between his walk south and his walk back, label the sides of your right-angled triangle.

# Tangent ratio: side lengths

## Notes and guidance

Teachers should start by modelling how to solve equations of the form  $a = \frac{b}{c}$

This helps students to be more confident when rearranging equations involving the tangent ratio to find missing side lengths. Teachers should model examples of finding both the opposite and the adjacent sides.

## Key vocabulary

Tangent	Opposite	Adjacent	Hypotenuse
Formula	Rearrange	Subject	

## Key questions

What does the 'tangent of an angle' mean?

How does it relate to similar triangles and scale factors?

Why do we need to use division when the missing side is the adjacent side?

## Exemplar Questions

Solve the following equations.

$\blacklozenge 4 = \frac{x}{20}$     
  $\blacklozenge 4 = \frac{20}{x}$     
  $\blacklozenge 2.8 = \frac{5.3}{x}$     
  $\blacklozenge 2.8 = \frac{x}{5.3}$

Whitney is finding length  $x$  in this triangle. Complete the stages of her workings:

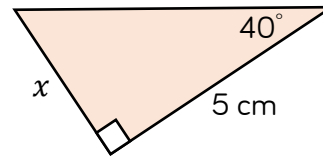

$$\begin{aligned} \tan \theta &= \frac{\text{opp}}{\text{adj}} \\ \tan ? &= \frac{x}{?} \\ ? \times \tan ? &= x \\ ? &= x \end{aligned}$$

Whitney thinks that she can use the same process to find  $x$  in this triangle.

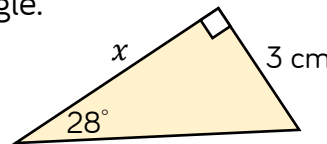

$$\begin{aligned} \tan 28 &= \frac{x}{3} \\ 3 \times \tan 28 &= x \\ 1.6 &= x \end{aligned}$$

The answer should be  $x = 5.6\text{cm}$ . Check her workings.

Copy and complete the following to find the missing length  $x$  in this triangle.

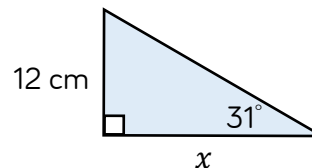

$$\begin{aligned} \tan 31 &= \frac{?}{?} \\ x \times \tan 31 &= ? \\ x &= \frac{?}{\tan 31} \end{aligned}$$

# Sine and cosine ratio: side lengths

## Notes and guidance

This small step starts with how to choose between sine and cosine to find a missing length. Teachers should emphasise that this is dependent on which side lengths are involved in the question. As an extension, students could explore the relationship between the sine and cosine ratios. Here, teachers could emphasise with students that the 'co' in cosine refers to the 'sine of the complement.'

## Key vocabulary

Sine	Cosine	Complement
Opposite	Adjacent	Hypotenuse

## Key questions

- How do we know which trigonometric ratio to use?
- Why do we always label the hypotenuse first?
- Why does  $\sin 30^\circ = \cos 60^\circ$ ?
- Can you find other pairs of angles where  $\sin x = \cos y$ ? What do you notice about these pairs of angles?

## Exemplar Questions

Teddy and Dora are calculating the missing length  $x$ .

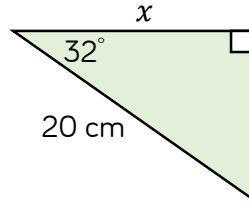

You should use sine.

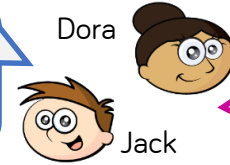

You should use cosine.

Who's right, Jack or Dora? Can they both be right? Explain your answer. Show that the missing value  $x$  is 17.0 cm.

Calculate the length of BD.  
Calculate the length of BC.

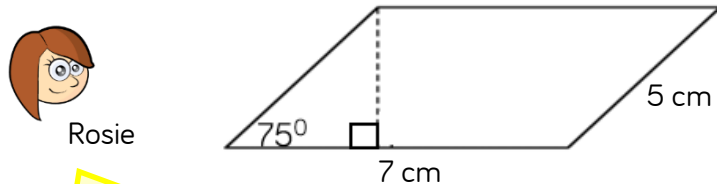
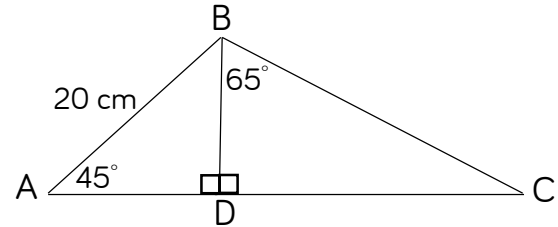

To the nearest whole, the area of the parallelogram is 35  $\text{cm}^2$

I think the area is 34  $\text{cm}^2$  to the nearest whole.

Who is correct?  
Support your answer with mathematical workings.

# Sin, cos and tan: side lengths

## Notes and guidance

Building on previous steps, students now need opportunities to identify which trigonometric ratio to use, particularly in problems which are less structured.

By starting with an exploration of all possible trigonometric ratios in a given diagram, students begin to become more flexible in their approach to finding missing side lengths.

## Key vocabulary

Sine	Cosine	Tangent	Opposite
Adjacent	Subject of formula		Hypotenuse

## Key questions

How do we know which trigonometric ratio to use?

Is there more than one method of finding a missing side length? Explain your thinking.

## Exemplar Questions

Dexter is writing down as many trigonometric relationships as he can find between the sides and angles in these right-angled triangles. Here is the start of his list:

$$\sin 63.4 = \frac{8}{4\sqrt{5}}$$

$$\tan 26.6 = \frac{4}{8}$$

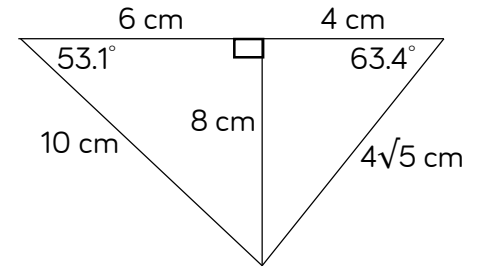

Complete Dexter's list. How many relationships did you find? Compare your list with a partner.

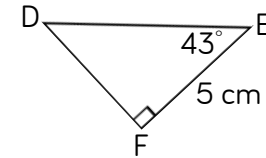
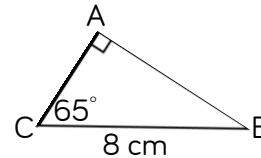

Which triangle has the largest perimeter?  
Calculate the difference between the perimeters.

ABCD is a rectangle.  
CD = 15 cm.  
CE is a straight line.  
Find the length CE.

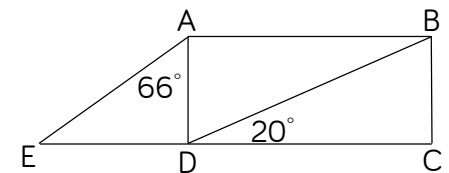

# Sin, cos and tan: angles

## Notes and guidance

When introducing the inverse, students might start by practising using their calculators to solve equations such as  $\sin \theta = 0.33$

It's important to expose students to different notation such as angle ABC and angle  $x$ . Ensure students are given examples where all 3 lengths of a right-angled triangle are given so that they can explore different methods of finding the same angle.

## Key vocabulary

Angle	Obtuse	Acute	Inverse
$\sin^{-1} x$	$\cos^{-1} x$	$\tan^{-1} x$	

## Key questions

- What is an inverse trigonometric function?
- What's the notation for an inverse trigonometric function?
- What's the difference between  $\sin x$  and  $\sin^{-1} x$ ?
- Why do we need to use an inverse trigonometric function to find a missing angle?

## Exemplar Questions

Use your calculator to find angle  $\theta$

■  $\sin \theta = 0.5^\circ$     
 ■  $\cos \theta = 0.27$     
 ■  $\tan \theta = 0.11$

Complete:

$\tan x = \frac{?}{?}$     
  $x = \tan^{-1} \frac{?}{?}$     
  $x = ?$

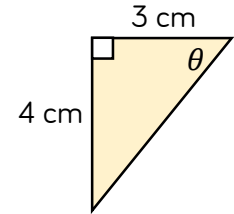

Here is Annie's method to find angle ABC. Explain the mistake that Annie has made.

Let angle ABC =  $\theta$

$$\sin \theta = \frac{8}{10}$$

$$\theta = \sin^{-1} \frac{8}{10}$$

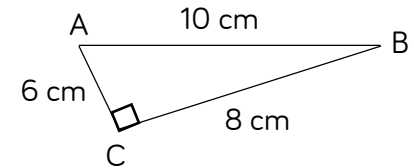
$$\theta = 53.13^\circ \text{ (2 dp)}$$

Is there more than one possible mistake? Find angle ABC.

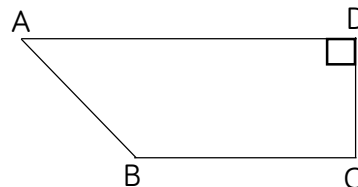

AD = 10 cm, BC = 7 cm  
and CD = 5 cm.  
Find angle ABC.

# Pythagoras' theorem



## Notes and guidance

Students are already familiar with Pythagoras' theorem from Year 9

This step reviews prior knowledge to ensure that students are confident in applying Pythagoras theorem.

Here, the aim is to use unfamiliar contexts to test depth of understanding.

## Key vocabulary

Area	Square
Square root	Right angle

## Key questions

How can we use side lengths to explore whether a triangle is right-angled?

What other topics could Pythagoras' theorem link to? (e.g. area, congruency, similar triangles, compass directions, distance between two co-ordinates.)

## Exemplar Questions

Explain what this diagram tells us about the side lengths of a right-angled triangle. If this diagram is drawn on 1 cm squared paper, work out the length of the hypotenuse.

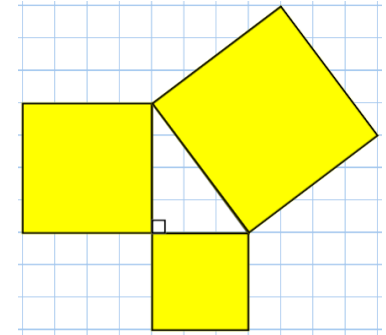

Sketch representations of right-angled triangles, labelling all side-lengths, to match each of the following calculations.

$$12^2 + 5^2 = 13^2$$

$$6^2 + ?^2 = 100$$

$$16^2 - 12^2 = ?^2$$

BDEF is a rectangle.  
Is triangle ABC right-angled?  
Show calculations to support your answer.

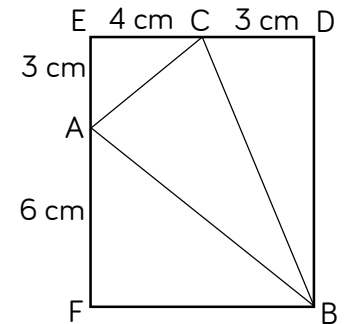

C is the centre of the circle.  
If AB = 28 cm, find the radius of the circle.

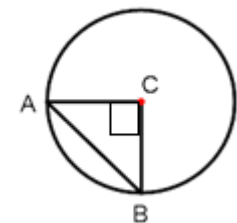

# Right-angled triangle problems

## Notes and guidance

In this small step, students make decisions about when to use trigonometric ratios and when to use Pythagoras' Theorem to solve problems.

They also realise that in some situations, either can be used. Scaffolding to support students through problems needs to be reduced as they become more confident.

## Key vocabulary

Pythagoras' Theorem	Similar	Hypotenuse
Adjacent	Opposite	

## Key questions

Which calculation to solve this problem is most efficient?

In this problem, is it more efficient to use Pythagoras' Theorem or trigonometry? Which has least steps?

## Exemplar Questions

Find each value of  $x$ .

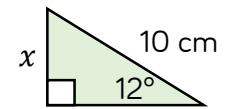
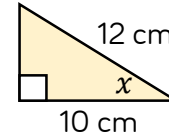
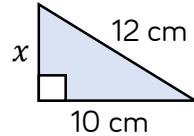

What's the same and what's different about each question?

ABCD is a trapezium. Angle BCD is  $48^\circ$   
 What side lengths can you work out?  
 What angles can you work out?  
 Calculate the area of the trapezium.  
 Calculate the perimeter of the trapezium.

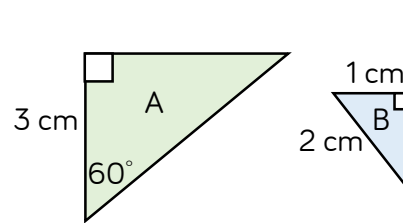
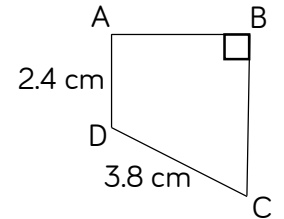

These triangles must be similar because triangle A is an enlargement of triangle B.



Dora is correct, but her reason is incomplete.

Show that the two triangles are similar by

- ▣ calculating the missing lengths on the two triangles.
- ▣ explaining why triangle A is an enlargement of triangle B.

# Key angles (1)

## Notes and guidance

In this small step, students are focusing on finding the exact trigonometric values of  $30^\circ$ ,  $60^\circ$  and  $45^\circ$ . Students start with relevant right-angled triangles to investigate these values, comparing their answers. Modelling how to use this information to solve right-angled triangle problems without a calculator is key. Students then use these facts to solve problems without use of a calculator.

## Key vocabulary

Surds	Exact value	Simplifying
-------	-------------	-------------

## Key questions

What do we mean by 'leave your answer as an exact value'?

What is a surd?

How do we simplify a fraction?

## Exemplar Questions

Use the right-angled triangle to find the exact values of:

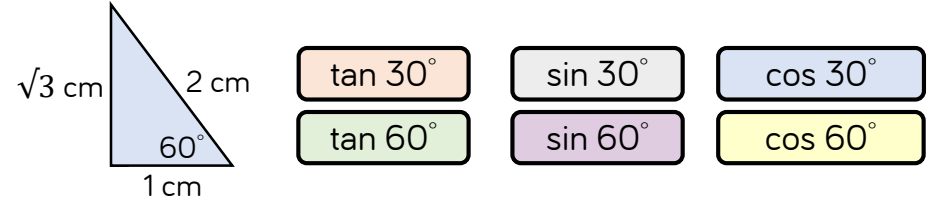

Look at your answers. What's the same and what's different?

Find the missing length and the missing angles in this triangle.

Use your triangle to find the exact values of:



Copy and complete:

$$\sin x = \frac{?}{?} = \frac{1}{2}$$

We know  $\sin ? = \frac{1}{2}$

So  $x = ?$

Without using a calculator, find the missing angles,  $x$ , in the following triangles.

Without using a calculator, find the exact values of  $x$  and  $y$ .

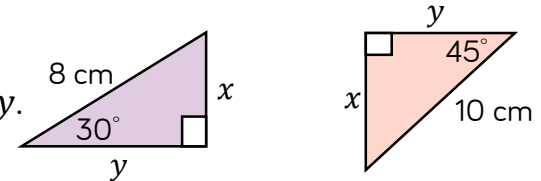



# Key angles (2)

## Notes and guidance

This step explores the sine, cosine and tangent of  $0^\circ$  and  $90^\circ$  and can be supported with either concrete resources and/or a dynamic geometry package. To deliver this, time will need to be allocated for student exploration and discussion, as well as pre-planned regular teacher-class discussion points where key ideas can be shared and built upon. The concept of infinity could be explored.

## Key vocabulary

Infinity	Approaching	Increasing
Decreasing	Limit	

## Key questions

When angle  $x$  decreases in size, what happens to the length of the opposite side?

Why can't we define  $\tan 90^\circ$ ?

Why do we say that a number divided by infinity is 0?

## Exemplar Questions

Use a dynamic geometry package to draw the triangle.



Now move the hypotenuse so that angle  $x$  is  $0^\circ$

This helps to show why  $\sin 0 = 0$

The opposite side is now 0 cm, so  $\frac{\text{opp}}{\text{hyp}} = 0$

Discuss why  $\tan 0 = 0$  and  $\cos 0 = 1$

Explore what happens when angle  $x$  in the diagram approaches  $90^\circ$  by using your calculator to complete this table.

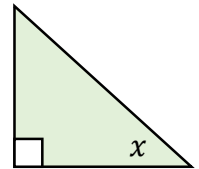

Round answers to the nearest whole number.

Angle ( $x$ )	89	89.9	89.99	89.999	89.9999	89.99999
Sin ( $x$ )						
Cos ( $x$ )						
Tan ( $x$ )						

Use your table to help you complete the following.

Discuss the reasons for these.

$\sin 90 =$

$\cos 90 =$

$\tan 90 =$

# Use trigonometry in 3-D shapes H

## Notes and guidance

Students start by recognising 3-D right-angled triangles in a 3-D shape. Using actual 3-D shapes or a dynamic geometry package is a useful way of exploring this.

The first exemplar question can be extended by adding on dimensions and/or angles and asking students to find missing dimensions and/or angles.

Also consider using cones and cylinders as examples.

## Key vocabulary

Prism	Plane	Slope	Isosceles
Midpoint	Diagonal	Square-based right pyramid	

## Key questions

- What is a prism? What is a plane in geometry?
- What is the angle between the edge HD and the face ABCD? (see diagram of cuboid)
- What is a square-based right pyramid?
- What does this tell us about vertex E?

## Exemplar Questions

Rosie writes a list of right-angled triangles that she can see in this cuboid:  
triangle ABC, triangle ACG, triangle BDF...

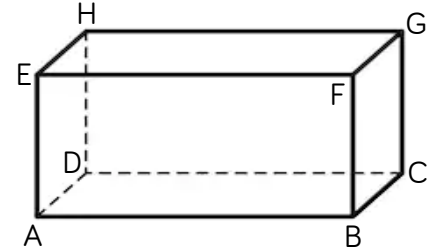

Continue her list. Can you get over 10 right-angled triangles?

The diagram shows a cube.  $AB = 10$  cm.

Find:

- ◆ Length AH
- ◆ Length BH
- ◆ Angle ABH

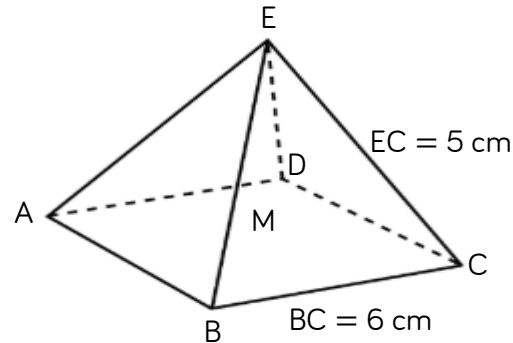
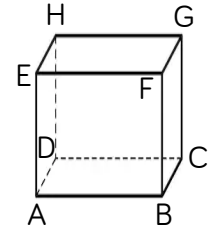

This is a square-based right pyramid. M is directly in the middle of the base. What does this tell us about vertex E and point M? Find length AC. Find the length MC and the height EM. Find the angle that the sloping face BEC makes with the base.

# Area of a triangle



## Notes and guidance

Check students understand how to use standard notation to label lengths and angles of a triangle.

It is important to emphasise that the formula may 'look different', depending on which angle is given, e.g. Angle C as opposed to Angle A.

Students progress to choosing the correct angle, based on the given sides, to substitute into the formula.

## Key vocabulary

Area	Perpendicular	Expression
Formula	Non-right-angled	

## Key questions

How do we label angles and sides in a non right-angled triangles? Why is a standard format helpful?

How does this formula relate to the standard formula for finding the area of a triangle:  $\frac{1}{2} \times \text{base} \times \text{height}$ ?

## Exemplar Questions

Find the perpendicular height and the area of the triangle.

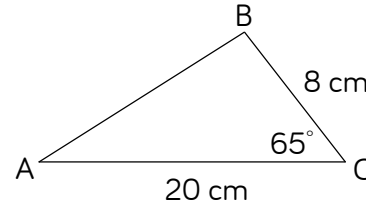

You can use algebra to find a formula for the area of a non-right angled triangle. The formula is  $\text{Area} = \frac{1}{2} ab \sin C$

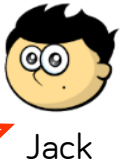

Jack

Are Tommy and Jack right? How can the triangle help you decide?

I think these will also work,  
 $\text{Area} = \frac{1}{2} bc \sin A$   
 $\text{Area} = \frac{1}{2} ac \sin B$



Tommy

Find the area of these triangles.

Find an expression for the area of this triangle.

Area of triangle RST = 100 m<sup>2</sup>  
 Find length RS.

Area triangle KLM = 25√3 cm<sup>2</sup>  
 Find angle θ

# Sine rule: finding lengths



## Notes and guidance

Students start by deriving the sine rule. This allows them to make connections to previous learning. They then consider correct substitution into the formula, particularly focussing on using the correct angle.

Finally, students begin to explore problems involving the sine rule. Scaffolding is provided in the exemplar questions, but this could be removed where appropriate.

## Key vocabulary

Opposite	Substitute	Equation
Formula	Rearrange	

## Key questions

How do we know which angle to substitute into the sine rule?

What if this angle isn't given? How can we find it?

What information do we need in a triangle in order to use the sine rule?

## Exemplar Questions

Complete the following.

In triangle BCX,  $h = a \sin B$

In triangle ACX,  $h = \underline{\hspace{2cm}}$

So,  $a \sin B = \underline{\hspace{2cm}}$

So,  $\frac{a}{\sin ?} = \frac{?}{\sin B}$

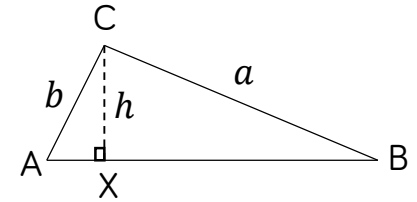

Ron is calculating the width of a river. He marks two points, A and B, on the river bank so that they are 40 m apart. He then marks on point C on the opposite river bed. The river beds are parallel.

- Find angle ACB.
- Use the sine rule to find length AC.
- Now calculate the width of the river.

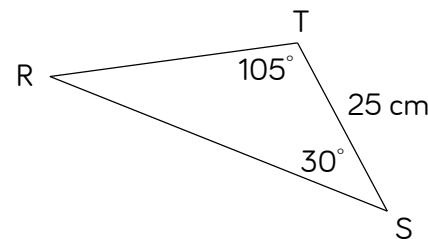
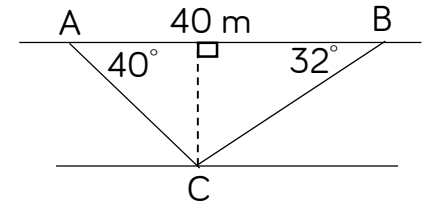

Annie wants to find side length RS. She uses the following method but then gets stuck as she doesn't know angle TRS.

$$\frac{t}{\sin 105} = \frac{25}{\sin ?}$$

Find angle TRS and then complete her workings to calculate length RS.

# Sine rule: finding angles



## Notes and guidance

Start by exploring different ways of writing the sine rule. Ensure students understand which rearrangement of the sine rule is most efficient depending on what they are trying to find.

Teachers could also consider  $\frac{\sin C}{c}$  when introducing this formula. Students also need to be reminded of the need to use the inverse function when finding an angle.

## Key vocabulary

Rearrange	Subject of the formula
Inverse	

## Key questions

How do you know which angle to substitute into the formula?

How do you know which length to substitute into the formula?

## Exemplar Questions



Dora reasons that if  $\frac{a}{\sin A} = \frac{b}{\sin B}$ , then  $\frac{\sin A}{a} = \frac{\sin B}{b}$

Show that Dora is correct by rearranging  $\frac{a}{\sin A} = \frac{b}{\sin B}$

Which rearrangement of the sine rule would you use to find a missing length?

Which rearrangement would you use to find a missing angle? Why?

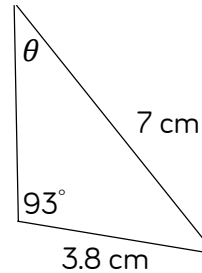

Amir calculates the missing angle  $\theta$

$$\frac{\sin \theta}{3.8} = \frac{\sin 93}{7}$$

$$\sin \theta = \frac{\sin 93}{7} \times 3.8$$

$$\sin \theta = 0.542113176$$

Amir finishes by stating:  $\theta = 0.54$  (2d.p)

He doesn't think this answer makes sense, where is his mistake?

Sketch the following triangle:

- Length AB = 12 cm
- Length BC = 9 cm
- Angle ACB = 103°

Now use the sine rule to calculate angle BAC.  
Now find the final missing angle and the final missing length.

# Cosine rule: finding lengths



## Exemplar Questions

### Notes and guidance

Teachers should guide the students through each step of deriving the cosine rule. Once they have derived the cosine rule, it's important that they understand that this formula can be used for any missing length (not just if it's labelled  $a$ ).

Then, after practising correct substitution to find a missing length using a calculator, revisit exact values to ensure familiarity of non-calculator use.

### Key vocabulary

Exact value	Formulae
Substitution	Cosine Rule

### Key questions

- Why isn't it always possible to use the sine rule?
- When finding a missing length, how do we know which angle to substitute into the formula?
- How do we know when to use the sine rule?
- How do we know when to use the cosine rule?

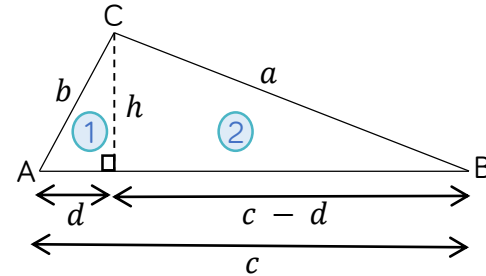

Use Pythagoras' Theorem in triangle 1 to express  $h^2$  in terms of  $b$  and  $d$

Using triangle 2, we know that  $h^2 = a^2 - (c - d)^2$   
Simplify this to show that  $h^2 = a^2 - c^2 + 2cd - d^2$

Equate the two expressions for  $h^2$  to deduce that  $a^2 = b^2 + c^2 - 2cd$

Using triangle 1, we know that  $\cos A = \frac{d}{b}$ , therefore  $b \cos A = d$

Substitute  $b \cos A = d$  into  $a^2 = b^2 + c^2 - 2cd$  to deduce that:  
 $a^2 = b^2 + c^2 - 2bc \cos A$

If:  $a^2 = b^2 + c^2 - 2bc \cos A$

Explain why:  $b^2 = a^2 + c^2 - 2ac \cos B$

What will the formula involving  $\cos C$  look like?

Find the exact value of length AB.

Use a calculator to find  $c$ .

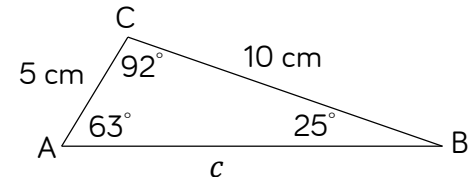

# Cosine rule: finding angles H

## Notes and guidance

Teachers could start with an example whereby students must correctly substitute numbers into the cosine rule and then rearrange to find the angle. This particularly supports students who struggle to remember the rearranged rule where  $\cos A$  is the subject of the formula. Then, teachers can help students to break down problems into stages before providing unstructured problems.

## Key vocabulary

Subject of the formula	Inverse
Rearrange	

## Key questions

- Why can't we use the sine rule in this triangle to find the missing angle?
- How do we know which numbers to substitute into the formula?
- Can we find all 3 missing angles in the triangle?

## Exemplar Questions

Teddy is calculating angle A in the triangle below. Complete his workings.

$$\begin{aligned} ?^2 &= ?^2 + ?^2 - 2 \times 13 \times 11 \times \cos A \\ &= 290 - ? \cos A \\ \cos A &= \frac{290 - ?}{?} \\ A &= \cos^{-1} ? \end{aligned}$$

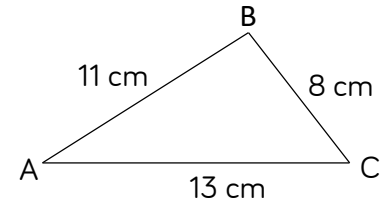

Rosie is calculating angle RQS.

What length in triangle RQS does she need to find first?

- Calculate this length.
- Calculate angle RQS.

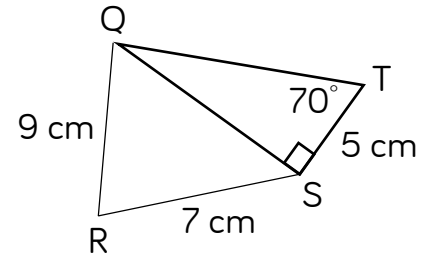

Sketch a triangle with side lengths 15 cm, 10 cm and 20 cm.

Use the cosine rule to work out the largest angle in the triangle.

# Choose sine or cosine rule (1) H

## Notes and guidance

Class discussion should explore which rule is most appropriate given specific information about the triangle. They then need support in unpacking problems into smaller more manageable steps.

Modelling how to break problems down, helps students to realise that problem solving is a process rather than a one-step response.

## Key vocabulary

Opposite	Adjacent	Segment
Sine Rule	Cosine Rule	Included Angle

## Key questions

How do you know whether to use the sine or cosine rule to solve a problem?

Look at the diagram. What do you know? What can you find out?

How can you break down the problem into smaller steps?

## Exemplar Questions

For each triangle, decide whether you can use the sine rule, cosine rule, or either rule, to find the labelled missing length or angle.

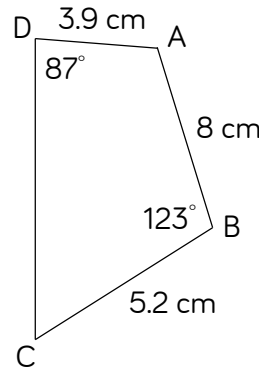
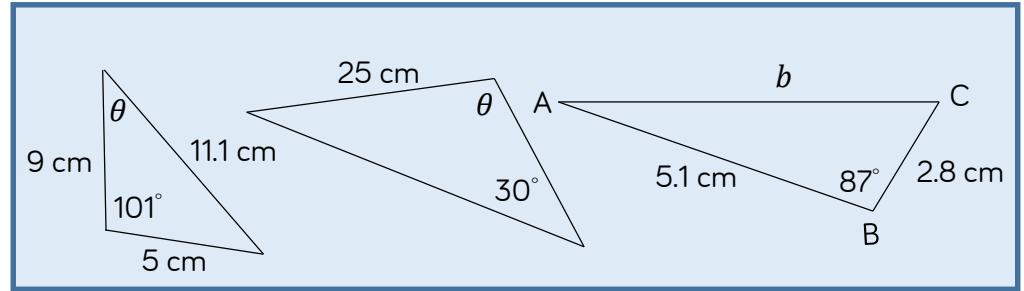

Mo is working out the area of the quadrilateral ABCD. He starts by breaking the problem down into smaller steps:

- Find area of triangle ABC
- Find length AC
- Find angle ACD
- Find angle DAC
- Find area of triangle ADC

Use Mo's steps to find the area of the quadrilateral.

Angle ADB =  $120^\circ$   
 Angle DAB =  $25^\circ$   
 Find length BD and angle CBD.

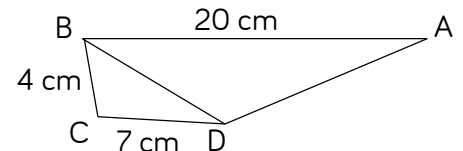



# Choose sine or cosine rule (2) H

## Notes and guidance

This continues to explore problems where students must choose between the sine rule and the cosine rule but extends to problem solving where application of other mathematical concepts, such as using ratios, is necessary.

The problems are unstructured, but teachers could add varying degrees of scaffold to support students.

## Key vocabulary

Sine Rule	Cosine Rule
-----------	-------------

## Key questions

Look at the diagram. What do you know? What can you find out?

Where could you start? What might your first step be?

How can you break down the problem into smaller steps?

What might you do if you feel 'stuck'?

## Exemplar Questions

A circular clock face has centre  $O$ .  
 The long hand is  $OA$  and 6 cm in length.  
 The short hand is  $OB$  and 4 cm in length.  
 The time is 4 o'clock.  
 Find the distance from  $A$  to  $B$ .



In a triangle, angle  $A$  : angle  $B$  : angle  $C$  are in the ratio  $3 : 5 : 10$   
 Find the length of side  $AC$  if side  $AB$  is 8 cm.

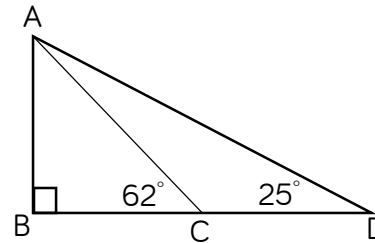

Find all the unknown angles in these triangles.  
 If  $CD = 20$  m, find all the unknown lengths.

$LM$  is parallel to  $PQ$ .  
 Calculate the length of  $PQ$ .

